

HP 16048A Test Leads

Operation Manual

Second Edition

Hewlett-Packard Japan, LTD.

HP PN 16048-90001



November 1998

Printed in: Japan

Notices

The information contained in this document is subject to change without notice.

This document contains proprietary information that is protected by copyright. All rights are reserved. No part of this document may be photocopied, reproduced, or translated to another language without the prior written consent of the Hewlett-Packard Company.

Hewlett-Packard Japan, LTD.

Kobe Instrument Division

1-3-2, Murotani, Nishi-Ku, Kobe-shi, Hyogo, 651-2241 Japan

© Copyright 1990, 1998 Hewlett-Packard Japan, LTD.

Manual Printing History

The manual's printing date and part number indicate its current edition. The printing date changes when a new edition is printed. (Minor corrections and updates that are incorporated at reprint do not cause the date to change.) The manual part number changes when extensive technical changes are incorporated.

1990 First Edition

November 1998 Second Edition

Safety Summary

The following general safety precautions must be observed during all phases of operation, service, and repair of this instrument. Failure to comply with these precautions or with specific WARNINGS elsewhere in this manual may impair the protection provided by the equipment. In addition it violates safety standards of design, manufacture, and intended use of the instrument.

The Hewlett-Packard Company assumes no liability for the customer's failure to comply with these requirements.

- **Ground The Instrument**

To avoid electric shock hazard, the instrument chassis and cabinet must be connected to a safety earth ground by the supplied power cable with earth blade.

- DO NOT Operate In An Explosive Atmosphere

Do not operate the instrument in the presence of flammable gasses or fumes. Operation of any electrical instrument in such an environment constitutes a definite safety hazard.

- Keep Away From Live Circuits

Operating personnel must not remove instrument covers. Component replacement and internal adjustments must be made by qualified maintenance personnel. Do not replace components with the power cable connected. Under certain conditions, dangerous voltages may exist even with the power cable removed. To avoid injuries, always disconnect power and discharge circuits before touching them.

- DO NOT Service Or Adjust Alone

Do not attempt internal service or adjustment unless another person, capable of rendering first aid and resuscitation, is present.

- DO NOT Substitute Parts Or Modify Instrument

Because of the danger of introducing additional hazards, do not install substitute parts or perform unauthorized modifications to the instrument. Return the instrument to a Hewlett-Packard Sales and Service Office for service and repair to ensure that safety features are maintained.

- Dangerous Procedure Warnings

Warnings, such as the example below, precede potentially dangerous procedures throughout this manual. Instructions contained in the warnings must be followed.

WARNING

Dangerous voltages, capable of causing death, are presenting this instrument. Use extreme caution when handling, testing, and adjusting this instrument.

Certification

Hewlett-Packard Company certifies that this product met its published specifications at the time of shipment from the factory. Hewlett-Packard further certifies that its calibration measurements are traceable to the United States National Institute of Standards and Technology, to the extent allowed by the Institution's calibration facility, or to the calibration facilities of other International Standards Organization members.

Warranty

This Hewlett-Packard instrument product is warranted against defects in material and workmanship for a period corresponding to the individual warranty periods of its component products. Instruments are warranted for a period of one year. Fixtures and adapters are warranted for a period of 90 days. During the warranty period, Hewlett-Packard Company will, at its option, either repair or replace products that prove to be defective.

For warranty service or repair, this product must be returned to a service facility designated by HP. Buyer shall prepay shipping charges to HP and HP shall pay shipping charges to return the product to Buyer. However, Buyer shall pay all shipping charges, duties, and taxes for products returned to HP from another country.

HP warrants that its software and firmware designated by HP for use with an instrument will execute its programming instruction when properly installed on that instrument. HP does not warrant that the operation of the instrument, or software, or firmware will be uninterrupted or error free.

Limitation Of Warranty

The foregoing warranty shall not apply to defects resulting from improper or inadequate maintenance by Buyer, Buyer-supplied software or interfacing, unauthorized modification or misuse, operation outside the environmental specifications for the product, or improper site preparation or maintenance.

IMPORTANT

No other warranty is expressed or implied. HP specifically disclaims the implied warranties of merchantability and fitness for a particular purpose.

Exclusive Remedies

The remedies provided herein are buyer's sole and exclusive remedies. HP shall not be liable for any direct, indirect, special, incidental, or consequential damages, whether based on contract, tort, or any other legal theory.

Assistance

Product maintenance agreements and other customer assistance agreements are available for Hewlett-Packard products.

For any assistance, contact your nearest Hewlett-Packard Sales and Service Office. Addresses are provided at the back of this manual.

Safety Symbol

General definitions of safety symbols used on the instrument or in manuals are listed below.



Instruction Manual symbol: the product is marked with this symbol when it is necessary for the user to refer to the instrument manual.

WARNING

This warning sign denotes a hazard. It calls attention to a procedure, practice, condition or the like, which, if not correctly performed or adhered to, could result in injury or death to personnel.

CAUTION

This Caution sign denotes a hazard. It calls attention to a procedure, practice, condition or the like, which, if not correctly performed or adhered to, could result in damage to or destruction of part or all of the product.

NOTE

Note denotes important information. It calls attention to a procedure, practice, condition or the like, which is essential to highlight.

Contents

1. Operation	
Product Description	10
Specifications	11
Typical Characteristics	12
Compensation for Fixture Residual Impedance Error	13
2. Service	
Maintenance	16

1 **Operation**

This operating note provides complete information on the HP 16048A Test Leads. The HP 16048A is shown pictorially in Figure 1-1, its physical dimensions are given in Table 1-1, and typical characteristics related to offset error are given in Table 1-2. To order additional copies of this operating note, use the part number listed on the rear cover.

Product Description

The HP 16048A consists of a direct attachment, 4-terminal pair type fixture which is equipped with four BNC (m) terminated-coaxial test leads. These test leads are used to attach user-fabricated test fixtures. DC bias levels of up to $\pm 40\text{V}$ can be applied to the HP 16048A. Cable length is 1 meter. The HP 16048A is shown in Figure 1-1.

Figure 1-1

Product Overview



Specifications

Table 1-1 Specifications of the HP 16048A

Function:	For use with 4 terminal-pair LCR Meters and Impedance Analyzers.
Connector Type:	BNC male
Cable Length:	Approximately 1m
Maximum Voltage:	$\pm 40V$ peak max. (AC+DC)
Weight:	315 g

Typical Characteristics

Table 1-2 Typical Characteristics

Incremental error at freq. ≥ 1 MHz	
Parameter reading error (%)	Offset value for D
$\pm 5 \times \left(\frac{f}{10}\right)^2$	$\pm 0.02 \times \left(\frac{f}{10}\right)^2$

NOTE

f is the measurement frequency in megahertz. The incremental errors calculated from the equation in the table for measurements at frequencies above 1 MHz are additive.

Figure 1-2

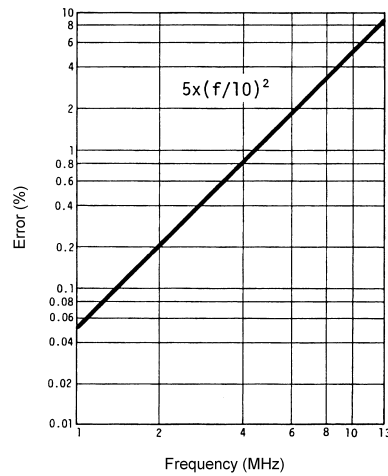

Parameter reading error vs frequency

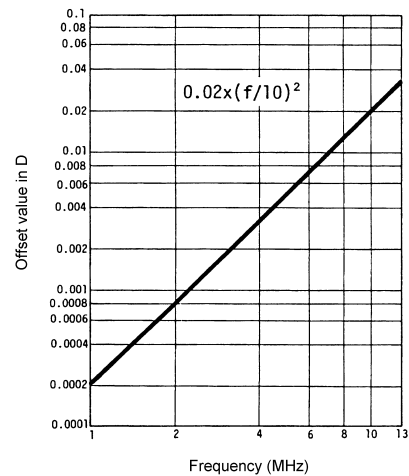

Offset value in D vs frequency

Compensation for Fixture Residual Impedance Error

The HP 16048A has inherent stray capacitance, residual inductance, and residual resistance that affect the accuracy of measured values. To compensate for, or negate, these residuals to minimize measurement error, the instrument's Open/Short compensation procedure should be performed. The procedure is given in the instrument's operating manual.

Operation

Compensation for Fixture Residual Impedance Error

2 **Service**

Maintenance

An exploded view of the HP 16048A (for parts identification) is shown in Figure 2-1. Do not disassemble any further than shown. Maintenance consists principally of cleaning contacts and replacing worn or damaged parts. Take special care when cleaning contacts. To order parts, use the Hewlett-Packard part numbers listed in Table 2-1. If a faulty part is located in an assembly that cannot be disassembled, order the next higher assembly or return the whole device to the nearest Hewlett-Packard Sales/Service Office for repair or replacement.

Figure 2-1 Parts Identification

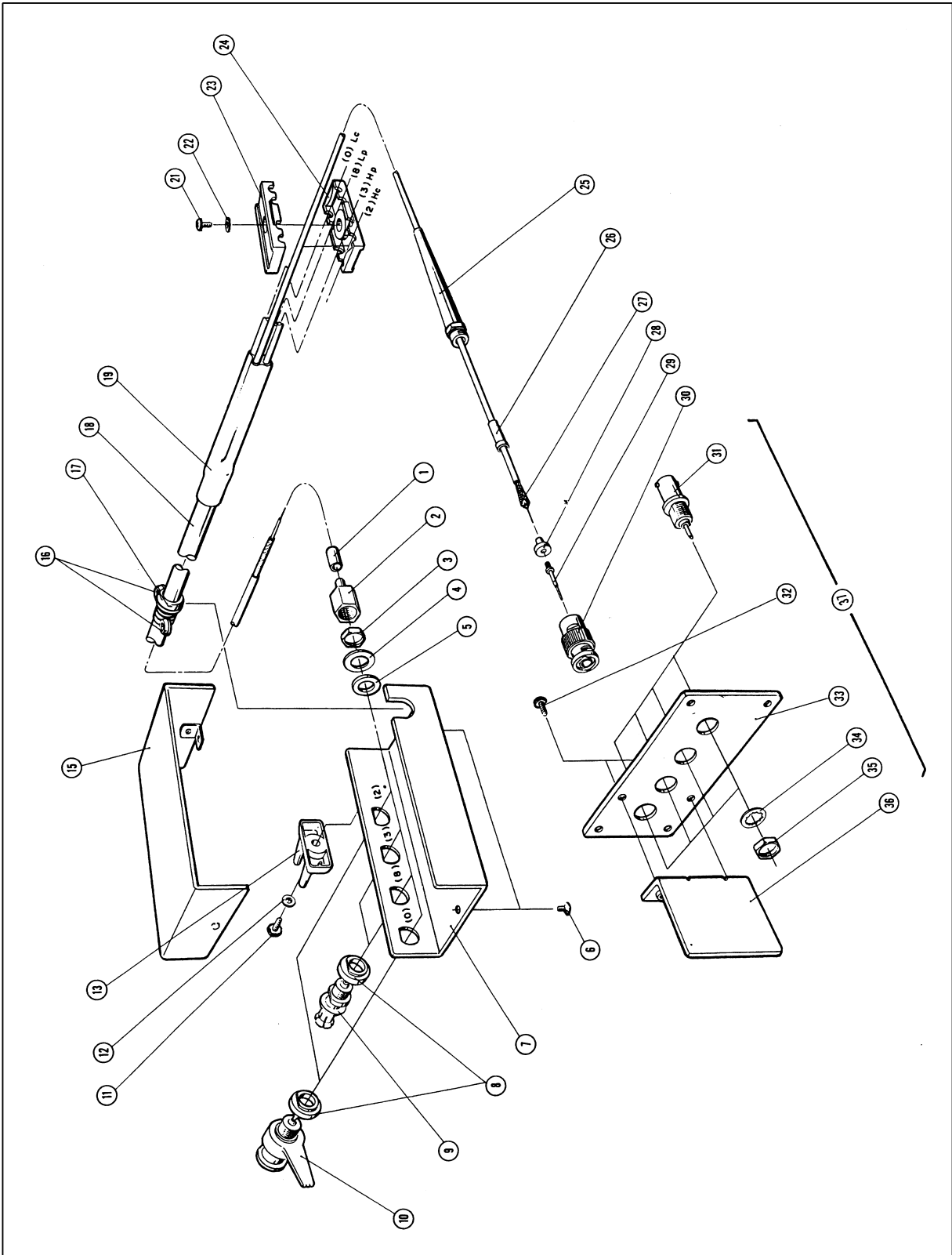

Table 2-1

Parts Identification

Reference	HP Part No.	Qty.	Description	Note
1	*	4	SLEEVE	
2	*	4	NUT	
3	*	4	NUT	
4	*	4	WASHER	
5	*	4	WASHER	
6	2360-0192	2	SCREW	
7	*	1	COVER-BOTTOM	
8	*	4	INSULATOR	
9	*	2	CONNECTOR-BNC	
10	*	2	CONNECTOR-BNC	
11	2200-0105	1	SCREW	
12	2190-0206	1	WASHER	
13	16047-40000	1	STOPPER	
15	16048-04000	1	COVER-TOP	
16	1400-01719	2	TIE RAP	
17	*	1	GROMMET	
18	*	1	CABLE	
19	*	1	BUSHING	
21	2360-0113	1	SCREW	
22	3050-0010	1	WASHER	
23	16021-50021	1	CABLE CRAMP	
24	16021-50022	1	CABLE CRAMP	
25	*	4	BOOT-BNC	
26	*	4	SLEEVE	
27	*	4	SLEEVE	
28	*	4	INSULATOR	
29	1250-0089	4	CONTACT	
30	1250-0052	4	CONNECTOR-BNC	
	16048-60010	1	TEST LEAD	1 thru 30

Reference	HP Part No.	Qty.	Description	Note
31	1250-0118	4	CONNECTOR-BNC FEMALE	
32	2360-0115	2	SCREW	1 thru 30
33	16032-10021	1	PLATE	
34	2190-0016	4	WASHER	
35	2950-0001	4	NUT	
36	16032-10022	1	PLATE	
37	16032-60001	1	BNC BRACKET	31thru36

*: Not separately replaceable. Order 16048-60010

Service
Maintenance